

486 Series Regulator

Single Stage

Ultra High Flow

*316L Stainless Steel
Barstock Body*

*Six-Port
Configuration*

*316L Stainless Steel
Diaphragm*

The 486 Series regulator applications are wide and varied including high flow purging, semiconductor manufacturing, manifold and line regulation.

Typical Applications

- *Ultra High Flow*
- *Bulk gas distribution systems*
- *Gas and liquid chromatography*
- *High purity carrier gases*
- *Zero, span, and calibration gases*
- *High purity chamber pressurization*
- *Liquefied hydrocarbon gas control*
- *Control of cryogenic gases*
- *Corrosive gas service*

Advanced Features

- *316L stainless steel barstock body*
Smooth surface finish
- *Rear panel mountable*
Versatile system configuration
- *Pressure ranges 0-15 to 0-250 PSIG*
Broad range of applications
- *3000 PSIG inlet pressure rating*
Safe use with high pressure cylinders



486-3301 shown

400 Advantage

- *PTFE diaphragm seal*
No possibility of gas contamination
- *ISOFLOW™ technology*
Internal equalization provides constant delivery pressure at high flows
- *316L stainless steel diaphragm*
No inboard diffusion
- *Low wetted surface area*
Minimal purge requirements
- *Field-adjustable pressure limit*
Safeguard downstream equipment
- *Pipe away relief valve*
Safely vent exhaust gases

Materials

Body
316L stainless steel barstock

Bonnet
Chrome-plated die cast zinc

Seat
PCTFE

Filter
50 micron 316L stainless steel

Diaphragm
316L stainless steel

Internal Seals
PTFE

Specifications

Maximum Inlet Pressure
3000 PSIG (210 BAR)

Temperature Range
-40°F to 140°F (-40°C to 60°C)

Gauges
2" diameter stainless steel

Ports
½" FPT (inlet/outlet)
¼" FPT (gauges/relief valve)

Helium Leak Integrity
1 x 10⁻⁸ scc/sec

Cv
1.0

Weight (486-3311-580)
5.06 lbs. (2.30 kg)

Flow Performance Curves

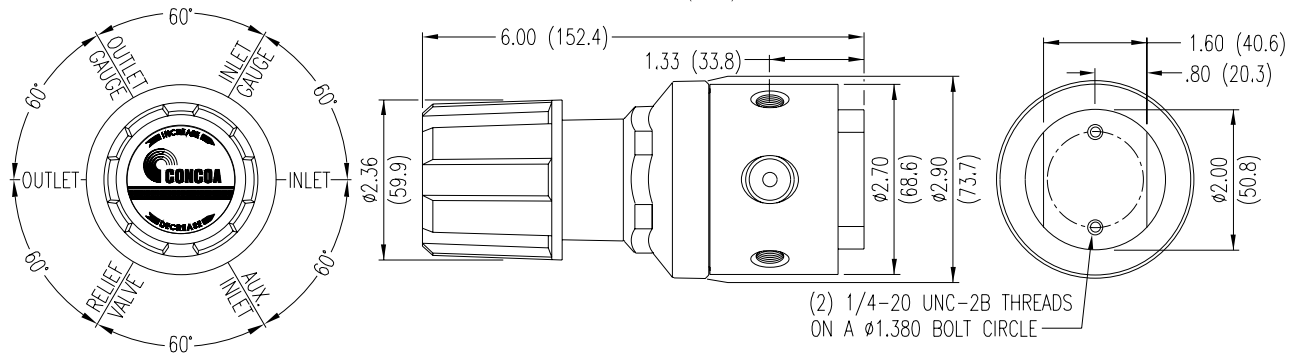
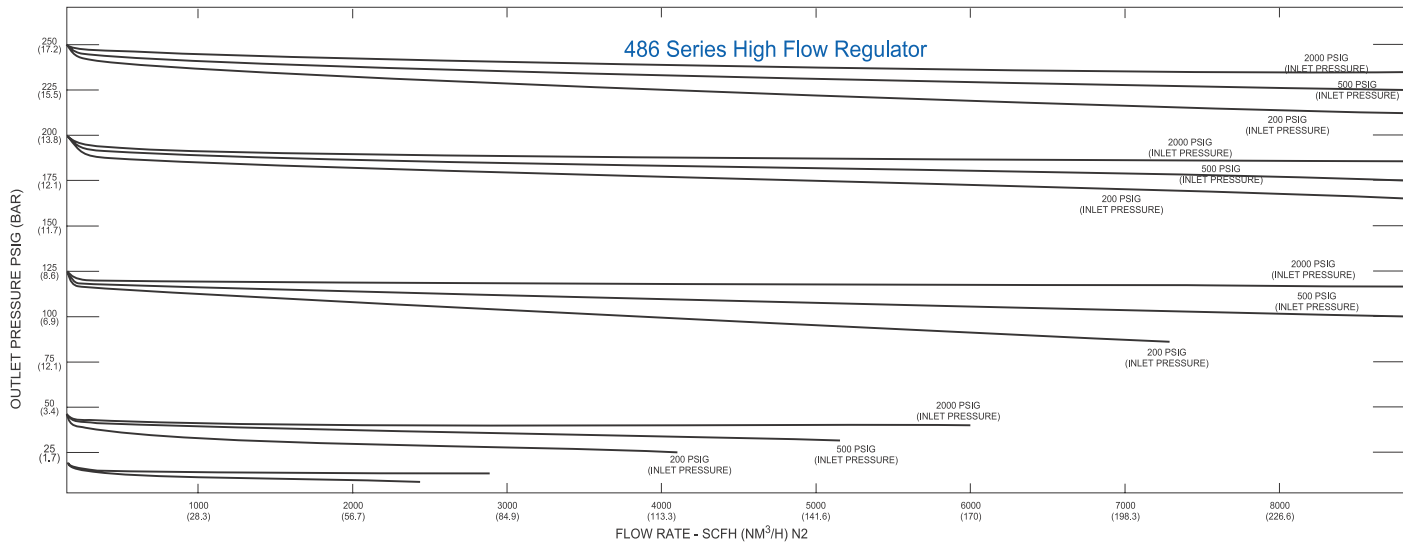

Ordering Information *(For information about how to use this table please see page 4.)*

486-	A		B	C	D	-Inlet	Options
Series 486	Outlet Pressure	Outlet Gauge	Inlet Gauge	Outlet Assemblies	Assembly/ Gauges	Inlet Connections	Installed Options
	1: 0-15	0-30 PSIG	0: None	0: 1/2" FPT Port	0: Bare Body	000: 1/2" FPT	M: Protocol Station
	2: 0-40	0-60 PSIG	3: 0-4000 PSIG	1: 1/2" Tube Fitting	1: Standard Assembly (PSIG/kPa Gauges)	TF8: 1/2" Tube	
	3: 0-120	0-200 PSIG	5: 0-1000 PSIG	P: 12mm Tube Fitting	2: Standard Assembly (BAR/PSIG Gauges)	M12: 12mm Tube	
	4: 0-200	0-400 PSIG	6: 0-400 PSIG			CGA	
	5: 0-250	0-400 PSIG	7: 0-200 PSIG			DIN 477	
			8: 0-600 PSIG			BS 341	
						and others available	