

The M80 range of auto change-over regulators are design specifically for the situation where the primary gas supply is a liquid vessel (eg. PLC, FLC, ...etc), and an emergency reserve supply is from one or more high pressure cylinders. When the gas supply in the vessel is exhausted the cylinder supply automatically takes over supplying the pipeline system. When the vessel is re-filled it automatically resets the regulator and takes over as the primary supply source.

The vessel used with a M80 regulator must be of the regulated outlet pressure type.

Because of the large number of options and operating requirements for manifold systems, the information contained in this leaflet should be used as a guide only. Please contact Gascon Systems to confirm your selection details.

## M80 FEATURES

- Two inlet gauges indicating supply in gas cylinder pressures at all times
- Large easy to read pipeline pressure gauge
- Pressure relief valve on primary regulators
- Change-over alarm connection port
- Modular inlet header system for expansion of systems
- Australian designed and manufactured.

## M80 ACCESSORIES

- Inlet purge valves for high purity applications
- Large selection of cylinder inlet leads to suit all types of applications, including copper coils, teflon and tefzel lined stainless steel flexible leads and convoluted stainless steel flexible leads
- Pressure switches for detecting cylinder change-over and/or line pressure failure
- Extension kits for use with multiple cylinder banks.
- Cylinder retaining brackets

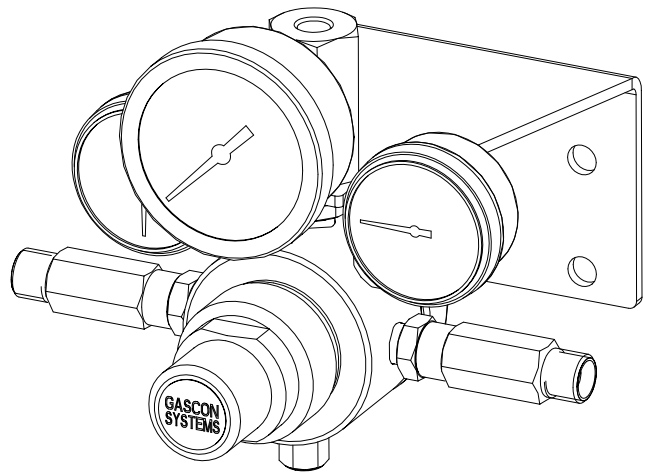

## M80 BASIC SPECIFICATIONS

Maximum Cylinder Inlet Pressure .....	200 Bar @ 15° C
Vessel Inlet Pressure .....	800kPa (Minimum), 1250kPa (Maximum)
Outlet Pressure Ranges .....	up to 800 kPa
Inlet Connection .....	3/8" BSP RH for industrial non-fuel gases
Outlet Connection .....	1/4" NPT Female
Temperature Operating Range .....	0-60° C
Weight.....	3.7 kgs
Basic Dimensions .....	210mm x 155mm x 195mm

Note: Vessel inlet pressure must be at least xxxkPa above desired outlet pressure

## BASIC DIMENSIONS

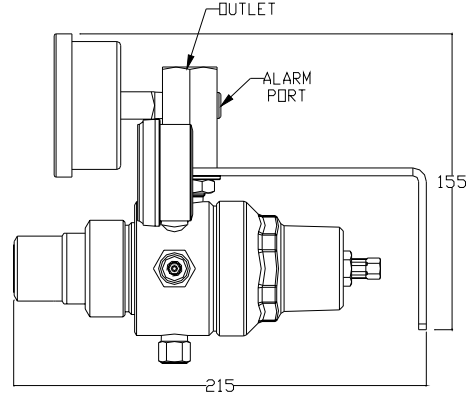
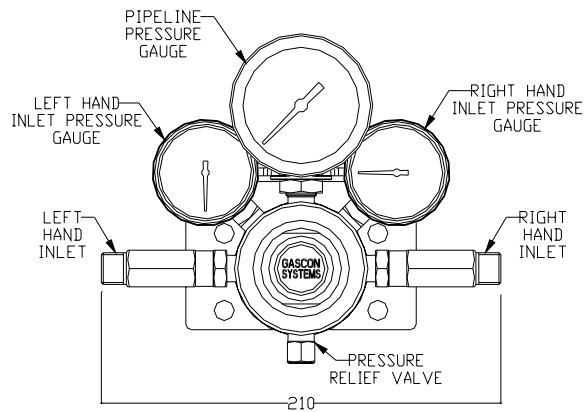

## FLOW PERFORMANCE CURVE (inlet pressure 2000kPa)

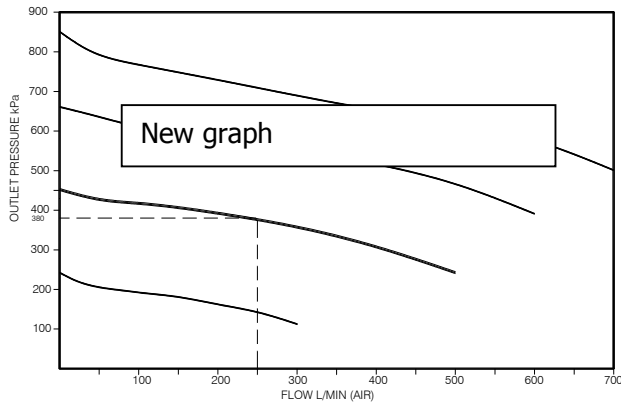

### Manifold System Design

When selecting components, the total system design must be considered to ensure safe, trouble-free performance. Component function, material compatibility, proper installation, operation, and maintenance are the responsibilities of the system designer and user.

It is advised that system installers and users be familiar with the recommendations detailed in appropriate national standard, (eg. Australian Standards AS2896 Medical Gas Systems, and AS4289 Oxygen and Acetylene Gas Reticulation Systems).

In the interests of continuous improvement, Gascon System Pty Ltd, reserves the right to change the specifications or design of any of its products without prior notice.

## ORDERING INFORMATION

MODEL	OUTLET PRESSURE (kPa) User defined	GAS	No. OF CYLINDERS	OPTIONS
<b>M80R</b>	Right Hand Vessel Left Hand Cylinder	AIR Air AR Argon CO <sub>2</sub> Carbon Dioxide	1x1 1 cylinder per bank 1PxP 1 manpack per bank 2x2 2 cylinders per bank	<b>01</b> – Pressure Switch Change-Over <b>02</b> – Pressure Switch Line Failure
<b>M80L</b>	Left Hand Vessel Right Hand Cylinder	N <sub>2</sub> O Nitrous Oxide N <sub>2</sub> Nitrogen OXY Oxygen OTHERS GASES by name or symbol	3x3 3 cylinders per bank 4x4 4 cylinders per bank	<b>04</b> – Inlet Purge Valves <b>05</b> – Inlet Contact Gauges

### ORDER EXAMPLES

M80R-600-N2-1x1  
M80L-800-OXY-2x1-01-

**GASCON**  
SYSTEMS

**Gascon Systems Pty. Ltd.** ABN: 74 716 626 338  
Unit 11, 1 Bell Street, PRESTON VIC 3072, AUSTRALIA  
**PH:** 61-3-9484 4190 **FX:** 61-3-9484 0368  
**Email:** sales@gascon.com.au  
<http://www.gascon.com.au>